

# BEL Pro Remote

MODEL RX75

## CUSTOM INSTALLED RADAR/LASER/SAFETY SYSTEM

### BEL Professional Series

BELTRONICS introduces an exclusive line of ultra-performance traffic radar/laser detectors guaranteed to drive your sales. The new BEL Pro Series combines 36 years electronics expertise and number-one rated technology for the ultimate in radar/laser protection.



- B. High-Performance radar antenna
- C. Interface conveniently connects all components
- D. Front laser receiver detects all laser signals
- E. Rear laser receiver detects all laser signals

USER DISPLAY PANEL



For  
Professional  
Installation  
Only!

# BELTRONICS™

Professional Series

■ PERMANENT INSTALLATION RADAR / LASER / SAFETY DETECTOR ■ DISCREET PROTECTION INCLUDES FRONT AND REAR LASER DETECTOR RECEIVERS ■ MICRO CONTROL PANEL WITH HIGH INTENSITY RED TEXT DISPLAY ■ PROFESSIONAL INSTALLATION ONLY ■

## HIGH INTENSITY TEXT DISPLAY

Ultra-bright text display confirms all alerts and feature selections.

### RADAR:

From BELTRONICS, the *engineering powerhouse*, comes the most sophisticated radar antenna to detect ALL traffic radar – including the new digital radar guns. Eight driver selectable features give the user comprehensive control for any driving environment. BEL *Pro Remote* comes complete with all mounting hardware for fast, custom installation.

### LASER:

FRONT and REAR Laser receivers containing multiple laser diodes detect energy far outside the main Laser beam for unprecedented sensitivity. The use of front and rear receivers ensure superior off-axis coverage and the widest “field-of-view”.

For additional Laser protection, you can augment the performance of BEL *Pro Remote* by custom installing BEL Laser Pro 904 (Model LP904) - a sophisticated Laser “blocking” system for unparalleled Laser protection. Call for details.

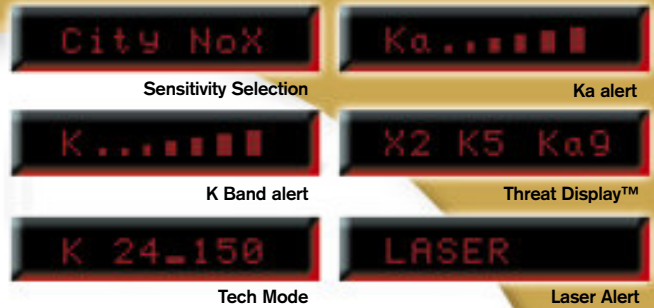

### Optional Pro Pack

MODEL RX75PP

Further customize the install process with these additional accessories:

**AMPLIFIED SPEAKER** enables voice alerts for radar and SWS messages. The increased audio level is ideal for convertibles, trucks, SUV's etc.



**DISCREET IN-DASH LED** allows the control panel to be hidden, while providing power-on (green) and alert (red) status.



**IN-DASH BEZEL** provides a custom-installed finish to any installation.

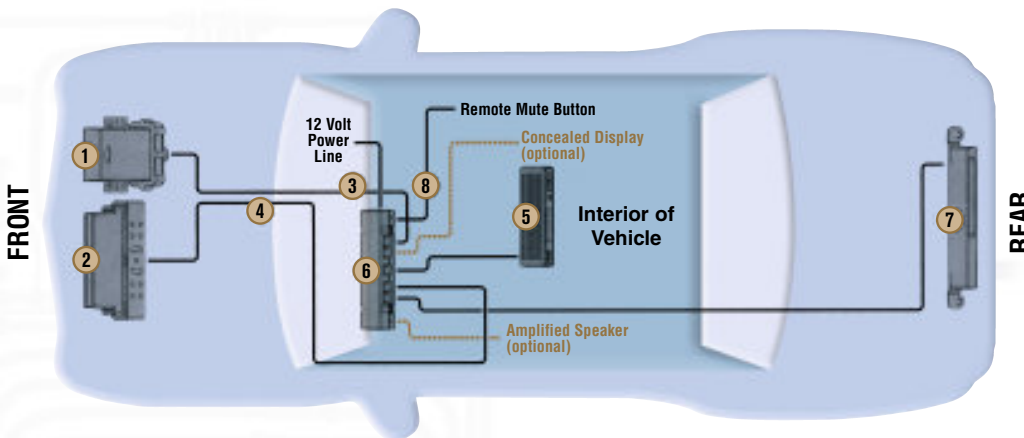

1. RADAR ANTENNA
2. FRONT LASER RECEIVER
3. CONNECTION OF RADAR ANTENNA
4. CONNECTION OF FRONT RECEIVER
5. USER DISPLAY PANEL
6. INTERFACE MODULE
7. REAR LASER RECEIVER
8. REMOTE MUTE BUTTON

**BELTRONICS™**  
*Professional Series*

BELTRONICS  
5442 West Chester Road, West Chester • Ohio • USA 45069  
800-541-4861 USA • [www.beltronicspro.com](http://www.beltronicspro.com)

Printed in Canada